

Paper Code : 07



ZONE TECH

Best Institute For Assistant & Junior Engineer

RPSC AE MAINS

SOLUTIONS

CIVIL ENGINEERING-II

Paper-IV

Exam Date :- **23 March 2025**

Click to Enroll <https://zonetech.in/rpsc-aen>

for more info Contact us at :

9828747676, 9462447676

PAPER-IV : CIVIL ENGINEERING PAPER - II

Total Marks: 200
Total Question: 37

Part - A

Note: Attempt all questions. Answer each question in 15 words. Each question carries 2 marks.

1. What is gauge pressure?

Sol. Gauge Pressure:-

- It is the value of pressure above atmospheric pressure.
- It is measured using manometer or Bourden gauge.

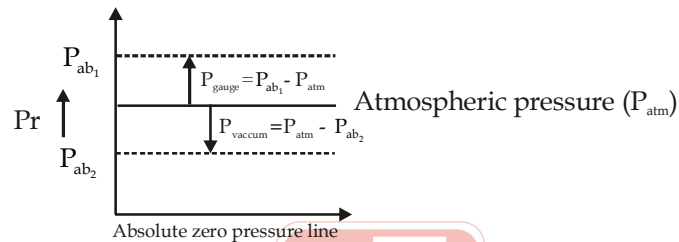

2. Why is it necessary in winter to use a lighter oil for automobiles than in summer? To what property does the term light refer?

Sol. In winter, temperature decreases which increases the viscosity of oil, making it thicker and harder to flow. Therefore, lighter oil (low viscosity) is used so that it can flow easily and provide proper lubrication. The term "light" refers to low viscosity (less resistance to flow).

3. What is stream function?

Sol. Stream Function (ψ):-

It is defined as a scalar function of space and time such that its partial derivative with respect to any direction gives the component of velocity at right angle to this direction (counter clock wise direction taken as positive).

$$\psi = f(x, y, t)$$

$$\frac{\partial \psi}{\partial x} = v$$

$$\frac{\partial \psi}{\partial y} = -u$$

4. List the fundamental lines of a Transit Theodolite.

Sol. Fundamental Lines of a Theodolite

The fundamental lines are imagined in a theodolite instrument are

1. Vertical Axis
2. Horizontal axis
3. Line of collimation
4. Axis of the altitude level tube
5. Axis of the plate level

5. Write any two conditions in which the use of sulphate resisting cement is recommended.

Sol.

- Marine construction and in coastal areas.
- In sewage treatment works
- Foundation

6. What is the investment cost of construction equipment?

Sol. It is the cost which is required to purchase the equipment at site for construction purpose and this cost is approximately 10 to 15% of the avg. investment cost.

7. Write the classification of lime.

Sol. According to Bureau of Indian Standard (BIS)-712 lime is classified into 6 categories.

Class A	Hydraulic Lime
Class B	Semi hydraulic Lime
Class C	Fat Lime
Class D	Magnesium Lime
Class E	Lean lime or kankar lime
Class G	Silicaceous lime

8. What do you mean by 'Mullion' in doors and windows?

Sol. **MULLION**:- This is the vertical member which is employed to sub-divide window vertically and provide support for Glazing, Resisting wind loads.

9. Write the defects in plastering.

Sol. (a) Cracking
(b) Blustering
(c) Efflorescence
(d) Flaking
(e) Grilling

10. Define Hortonian runoff.

Sol. Hortonian runoff indicates infiltration excess over land flow which occurs when intensity of rain fall is more than soil water absorption capacity.

11. What is meant by Flow duty and Quantity duty?

Sol. **Flow duty**- It is also called as canal duty which represents the area of field in hectare that can be irrigated by discharge of 1 cumec.

Quantity duty- It is also called storage duty which represents the area of field in hectares that can be irrigated by one million cubic meter of stored water.

12. What is meant by 75% dependable yield of a catchment?

Sol. It is the volume of water which represents surface runoff which is expected to be equal or exceed at the outlet 75% of the time/years.

13. Define Instantaneous Unit Hydrograph (IUH).

Sol. **Instantaneous Unit Hydrograph**:- It is the limiting case of a unit hydrograph when the duration of hydrograph is tending towards zero.

It is indicative of catchment storage characteristics.

14. What is Stopping Sight Distance?

Sol. **Stopping sight distance or Absolute min. sight distance or Non - passing sight Distance :**

It is the minimum distance required to stop the vehicle before collision to the object which is visible ahead to the driver on the road.

$$S.S.D = \text{Lag distance} + \text{Braking distance}$$

$$S.S.D = v \times t + \frac{v^2}{2fg} \rightarrow \text{If braking efficiency is 100\%}$$

Where, $v \rightarrow$ Speed in m/sec

$t \rightarrow$ Reaction time in sec

$f =$ Longitudinal coefficient of friction (0.35 to 0.40)





ZONE TECH
Best Institute For Assistant & Junior Engineer

RPSC-AE

Urban Development and Housing

UDH

शिखर
Batch

Offline

&

LIVE

Live From Classroom



30 March 2026



08:00 AM

LIVE Batch Features

- 500+ hours of Technical & 200+ hours of Non-Technical Video Lectures of LIVE from OFFLINE CLASS ROOM
- Chapter Wise & topicwise Daily Practice Paper (DPP) / WORKBOOK solution videos
- 40 Mock Papers in exam styled question format for practice
- Exclusive access to the Tejas practice batch featuring 5000+ standard Technical Que and 2000+ Non-Tech Que (Limited Time offer)
- Meet your mentors anytime at our offline centres
- CLASSNOTES, DPP (Workbook), Question Booklet in PDF format of all Subjects .
- Telegram Group for Enrolled Students for Doubt Solving

for more info Contact us at :

9828747676, 9462447676

15. Define camber and gradient of roads.

Sol. **CAMBER:** It is the transverse slope provided to road surface to drain out the water from it.
Gradient or slope : It is the rise or fall of the road along the longitudinal direction of the road.

16. Name any two methods of collecting the data for Origin and Destination (O&D) studies in traffic engineering.

Sol. 1. Vehicle number or licence plate method.
 2. Road side interview method.
 3. Home interview method
 4. Tag on car method.

17. Define a tack coat in a bituminous course.

Sol. It is the application of low viscous bituminous. Material applied to an existing pavement surface before the new bituminous layer.

18. Since sewage contains solid particles, how can we prevent clogging and silting problems in sewers?

Sol. To avoid the clogging problem in sewer's we should maintain the self cleansing velocity around 0.45 m/sec.

To prevent sitting problem we should provide grit chamber to separate heavier inorganic solids (Sand and Gravel).

19. Explain the significance of E. coli in water analysis.

Sol. It is the most effective bacterial indicator which is used to check the quality of waste water and it is termed as Escherichia Cali (E. Cali).

20. What is meant by self-purification of streams?

Sol. It is the natural process which may be Physical, Chemical and Biological by which a polluted water can restore its original quality over the distance by the Dilution and Oxidation process.

Part - B

Note: Attempt all questions. Answer each question in 50 words. Each question carries 05 marks.

21. A 1 m wide and 1.5 m deep rectangular plane surface lies in water in such a way that its plane makes an angle of 30° with the free water surface. Determine the total pressure and position of centre of pressure when the upper edge is 0.75 m below the free water surface.

Sol.

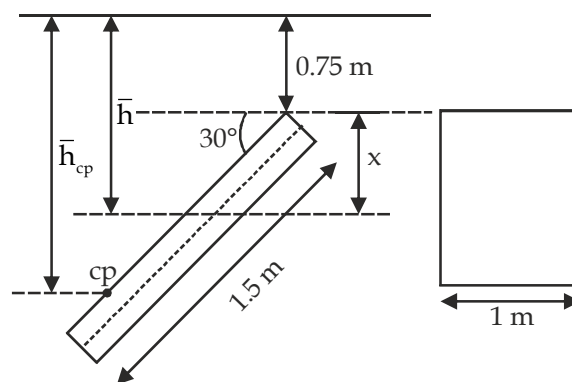

$$\text{Total pressure (f)} = \rho g \bar{h} A$$

$$\therefore \bar{h} = 0.75 + x$$

$$\bar{h} = 0.75 + \left(\frac{1.5}{2} \times \sin 30^\circ \right) = 1.125 \text{ m}$$

$$\therefore F = 1000 \times 9.81 \times 1.125 \times (1.5 \times 1) = 16.55 \text{ kN}$$

The depth of center of pressure is given by

$$\bar{h}_{cp} = \bar{h} + \frac{I_a \sin^2 \theta}{\bar{h}A}$$

$$\begin{aligned} \bar{h}_{cp} &= 1.125 + \frac{\left(\frac{bd^3}{12}\right) \sin^2 30}{1.125 \times bd} = 1.125 + \frac{\left(\frac{d^2}{12}\right) \times \sin^2 30}{1.125} \\ &= 1.125 + \frac{1.5^2 \times \sin^2 30}{12 \times 1.125} \\ &= 1.167 \text{ m} \end{aligned}$$

22. Define Metacentre and Metacentric Height. How can you check the stability of floating body based on Metacentre location?

Sol. **Metacenter (M):-** It is the point on vertical axis of the body at which the line of action of buoyant force cuts the vertical axis of the body.

- Metacenter can lie inside or outside the body.
- It is the point about which the body oscillates.

→ **Metacentric Height (GM):-**

It is the height of metacenter above the center of gravity.

- GM = + ve → Stable
- GM = 0 → Neutral
- GM = - ve → Unstable

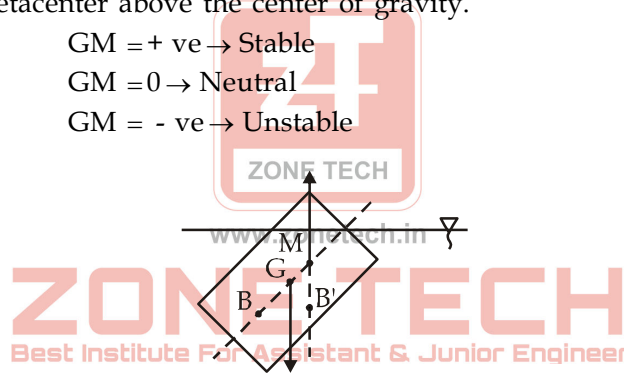

GM = Metacentric height

In general

$$GM = BM - BG$$

$$GM = \frac{I}{V_{\text{Displaced}}} - BG$$

Where, I=MOI of the surface of body cutted by the free surface of fluid.

Stability Condition of Floating Body

Stability depends on the relative position of M and G:

1. Stable Equilibrium:
 - If M is above G → GM > 0
 - Body returns to original position after tilt
2. Unstable Equilibrium:
 - If M is below G → GM < 0
 - Body overturns
3. Neutral Equilibrium:
 - If M coincides with G → GM = 0
 - Body stays in new position.

23. What is satellite station? Draw and derive the reduction to centre concept when the satellite station is located on left side of main station.

Sol. **Satellite Station**

A satellite station is a subsidiary station established near the main triangulation station when the main station itself is not suitable for observations (due to obstruction, inaccessibility, or lack of intervisibility). Observations are taken from the satellite station, and then reduced to the main station.

Reduction to Centre Concept

When observations are taken from a satellite station instead of the main station, we must reduce (correct) the observed angles so that they represent angles as if measured at the main station (centre).

Case: Satellite Station on LEFT side of Main Station

S (Satellite station)

O (Main station)

O = Main station (centre)

S = Satellite station (left of O)

P, Q = other stations observed

Observed vs Required Angle

Observed angle at satellite station = $\angle PSQ$

Required angle at main station = $\angle POQ$

Reduction Formula (Left Side Case)

Correction is applied as:

Where:

α = angle subtended by OS at point P

β = angle subtended by OS at point Q

If satellite station is on left side correction = $+\alpha - \beta$

If on right side correction = $-\alpha + \beta$

Corrections depend on relative positions of points

Explanation

Because observations are taken from S instead of O, there is a shift in angle. So we apply small angular corrections (α and β) to bring the measured angle back to the true centre (O).

24. Explain any five defects in clay bricks.

- Sol.
- (1) **Chuffs:** When rain water falling on hot surface of brick then a deformation as crack take place on surface of brick is known as Chuffs.
 - (2) **Efflorescence:** This is caused because of alkalies present in bricks clay when bricks soaked in water then after drying grey or white powder patches appear on the brick surface.
 - (3) **Blisters:** Broken blisters are generally caused on the surface of brick due to air imposed during their moulding.
 - (4) **Black core:** When brick-clay contains bituminous matter or carbon and not completely removed by oxidation then the results in black core.
 - (5) **Over-burnt brick:** If the bricks are overburnt a soft matter mass is produced and the bricks loose their shape. These are not suitable for construction work.



ZONE TECH
Best Institute For Assistant & Junior Engineer

RSSB-JE

संकल्प
Batch

CIVIL ENGG. B.TECH



30 March 2026

Offline
&

LIVE

Live From Classroom



08:00 AM

LIVE Batch Features

- 500+ hours of Technical & 150+ hours of Non-Technical Video Lectures of LIVE from OFFLINE CLASS ROOM
- Chapter Wise & topicwise Daily Practice Paper (DPP) / WORKBOOK solution videos
- 40 Mock Papers in exam styled question format for practice
- Exclusive access to the Tejas practice batch featuring 3000+ standard Technical Que and 2000+ Non-Tech Que (Limited Time offer)
- Meet your mentors anytime at our offline centres
- CLASSNOTES, DPP (Workbook), Question Booklet in PDF format of all Subjects .
- Telegram Group for Enrolled Students for Doubt Solving

for more info Contact us at :

9828747676, 9462447676

25. Explain coping and corbelling.

Sol. Coping and corbelling are used in building construction

Coping:

Coping is an element built on the top of boundary walls, parapet walls or any other open walls. It is made with concrete, metal etc. coping prevent rain water seepage into the wall and direct the water away from the wall.

Corbelling:

It is used to support a beam, balcony, floor slab etc. it is also used for decorative purpose. It is a technique where each stone course steps slightly outward from the face of the wall.

26. Define apparent, effective and bulk specific gravity of coarse aggregates in bituminous mix. Explain the interrelation also.

Sol. **Apparent specific gravity or Theoretical specific gravity (G_T):** It is the specific gravity with out considering air void or the ratio of the oven-dry mass of aggregate to it's volume excluding all permeable pores.

$$G_T = \frac{w_{CA} + w_{FA} + w_{FM} + w_{BM}}{\left[\left(\frac{w_{CA}}{G_{CA}} \right) + \left(\frac{w_{FA}}{G_{FA}} \right) + \left(\frac{w_{FM}}{G_{FM}} \right) + \left(\frac{w_{BM}}{G_{BM}} \right) \right]}$$

$$w_T = w_{CA} + w_{FA} + w_{FM} + w_{BM}$$

$$G_T = \frac{w_T}{\left[\left(\frac{w_{CA}}{G_{CA}} \right) + \left(\frac{w_{FA}}{G_{FA}} \right) + \left(\frac{w_{FM}}{G_{FM}} \right) + \left(\frac{w_{BM}}{G_{BM}} \right) \right]}$$

Bulk specific gravity or Actual specific gravity (G_m): It is the specific gravity with considering air void or the ratio of the oven-dry mass of aggregate to its total volume.

Effective specific gravity (G_{sb}): Used for calculating the effective binder content and for calculating the theoretical maximum specific gravity (G_{mm}) of the mixture.

Apparent specific gravity > Effective specific gravity > Bulk specific gravity

27. Discuss the salient features of Kennedy's theory for the design of earth channel based on the critical velocity approach and mention the limitations.

Sol. **Kennedy's Theory:-**

- Kennedy was an executive engineer in Punjab P.W.D. He studied existing canal system of upper Bari Doab which did not show silting and scouring in the previous few years.
- As per his observations he concluded that the silt carrying power of a canal is dependent upon generation of eddies. These eddies are generated at the bed of canal.
- From his observation he defined a critical velocity (V_0) at which neither silting nor scouring takes place.

$$V_0 = C_1 y^{C_2}$$

Where V_0 = Critical Velocity (m/s)

$$C_1 = 0.55 \text{ (Constant)}$$

$$C_2 = 0.64 \text{ (Constant)}$$

$$y = \text{Depth of flow (m)}$$

- The above formula is not valid for the entire country therefore Kennedy proposed a modified form of critical velocity by introducing a factor called as critical velocity ratio which depends upon silt grade.

$$V_0 = m \cdot C_1 \cdot y^{C_2}$$

where m = CVR (Depends upon size, type of silt)

m = Critical Velocity Ratio (If m value not given we use $m = 1$)



Limitations of Kennedy Theory:-

1. Kennedy stated that eddy's are formed only on the bed surface but in actual eddies are developed in sides also.
2. Kennedy did not give any mathematical expression to calculate the bed slope of canal.
3. He did not gave any expression for critical velocity ratio.
4. He did not gave any expression to calculate the velocity of flow and used chezy's equation.

28. The peak of flood hydrograph due to a 3-h duration isolated storm in a catchment is 270 m³/s. The total depth of rainfall is 5.9 cm. Assuming an average infiltration loss of 0.3 cm/h and a constant base flow of 20 m³/s, estimate the peak of the 3-h unit hydrograph (UH) of this catchment. If the area of the catchment is 567 km², determine the base width of the 3-h unit hydrograph by assuming it to be triangular in shape.

Sol.

Peak of flood hydrograph = 270 m³/sec.

Duration (tr) = 3h, Total rainfall depth = 5.9 cm

ϕ = 0.3 cm/h, Constant base flow = 20 m³/sec.

Area of catchment (A) = 567 km²

Peak of D.R.H. = Q_p = Flood peak - Base flow
 = 270 - 20 = 250 m³/sec.

Depth of effective rainfall (R)

$R = P - (\phi \times tr) = 5.9 - (0.3 \times 3) = 5 \text{ cm}$

Peak of 3-h unit hydrograph (p_p) = $\frac{250}{5} = 50 \text{ m}^3 / \text{sec.}$

Base width of triangular unit hydrograph-

Volume of unit hydrograph = Area of catchment \times 1 cm runoff depth

$\frac{1}{2} \times \text{Base} \times \text{Height} = A \times 0.01 \text{ m}$

$\frac{1}{2} \times (t_b \times 3600) \times \text{Peak of 3h U.H.} = 567 \times 0.01 \text{ m}$

$\frac{1}{2} \times (t_b \times 3600) \times 50 = 567 \times 10^6 \times 0.01$

$t_b \times 3600 \times 25 = 5670000$

$t_b = \frac{5670000}{3600 \times 25} = 63 \text{ hr.}$

$t_b = 63 \text{ hr}$

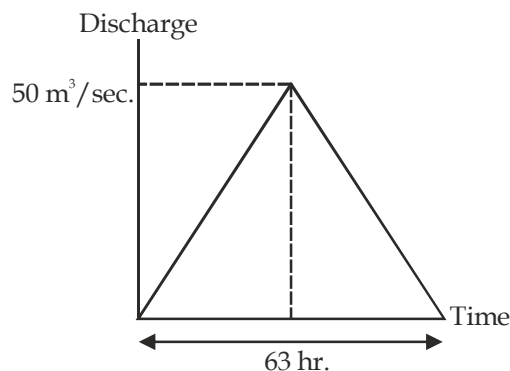

29. State any five differences between roundabouts and rotary intersections.

- Sol.
1. Round about is a morden traffic inter section and rotary intersection is a older and larger circular intersection.
 2. Round about design for low speed vehicles and rotary intersection is design for high speed vehicles.
 3. Round about is in smaller size but rotary is in bigger size.
 4. Round about is safer but rotary is less safe because high speed vehicle.
 5. Round about have low capacity but rotary have high capacity of passing vehicles.

30. A dual four-lane carriageway has traffic of 6000 CVPD in predominant direction before construction. The project took 5 years for completion. Considering the growth rate of 6.5% and vehicle damage factor of 5.30, calculate the design traffic for 20-year duration. Assume lane distribution factor = 0.45. [The traffic at the end of construction may be estimated as $A = A_i (1+r)^m$ where m is construction period and A_i is the number of commercial vehicles initially counted.]

- Sol.
- Time in completion = 5 yr.
 Design life (n) = 20 yr.
 Growth rate (r) = 6.5%
 Initial traffic = 6000 CVPD
- Total traffic per day after construction = $6000 (1 + 0.065)^5 = 8221$ Vehical per day
 Lane distribution factor = 0.45
 Vehicle damage factor = 5.30
- $$\text{Cummulative standard axle} = \frac{365 \times A \times Df [(1+r)^n - 1]}{r}$$
- $$= \frac{(365)(8221)(0.45)(5.30)[(1 + 0.065)^{20} - 1]}{0.065} \times 10^{-6}$$
- www.zonetech.in
 = 277.85 Million Standard Axle.

31. It is required to supply water to a population of 20,000 at a per capita demand of 150 litres per day. The disinfectant used for chlorination is bleaching powder, which contains 30 percent of available chlorine. Determine how much of bleaching powder is required annually at the waterworks, if 0.3 ppm of chlorine dose is required for disinfection?

- Sol. Given
- Population (P) = 20000
 Demand of water = 150 Litres/capita/day
 Chlorine in bleaching powder = 30%
 Chlorine does require for disinfection = 0.3 ppm or 0.3 mg/l
 Annually water used by 20000 population
 = Population (P) × Per capita water demand per day × 365
 Annually water used by 20000 population
 = 20000 × 150 × 365 = 1095 × 106 litres
 Annually water used by 20000 population = 1095 × 106 litres
 Chlorine required annually for disinfection = 1095 × 106 × 0.3 mg
 Chlorine required annually for disinfection = 3285 × 105 mg
 Chlorine required annually for disinfection = 3285 × 102 g
 Chlorine required annually for disinfection = 328.5 kg
 Chlorine required annually for disinfection
 = Bleaching powder required annually × Chlorine available in bleaching powder
 Bleaching powder required annually
 = Bleaching powder required annually = 1095 kg
 The bleaching powder required annually for water work is 1095 kg.



ZONE TECH
Best Institute For Assistant & Junior Engineer

RSSB-JE

आकाश
Batch

CIVIL ENGG. DIPLOMA



30 March 2026

Offline
&

LIVE

Live From Classroom



08:00 AM

LIVE Batch Features

- 400+ hours of Technical & 150+ hours of Non-Technical Video Lectures of LIVE from OFFLINE CLASS ROOM
- Chapter Wise & topicwise Daily Practice Paper (DPP) / WORKBOOK solution videos
- 30 Mock Papers in exam styled question format for practice
- Exclusive access to the Tejas practice batch featuring 2000+ standard Technical Que and 2000+ Non-Tech Que (Limited Time offer)
- Meet your mentors anytime at our offline centres
- CLASSNOTES, DPP (Workbook), Question Booklet in PDF format of all Subjects .
- Telegram Group for Enrolled Students for Doubt Solving

for more info Contact us at :

9828747676, 9462447676

32. Briefly explain the mechanical aeration method in activated sludge process.

Sol. Mechanical Aeration in Activated Sludge Process

Mechanical aeration is a surface aeration method used to supply oxygen to wastewater so that microorganisms can grow and treat the sewage.

Working Principle:

Mechanical aerators use electrically powered devices like propellers, impellers, or paddles. These rotate and create strong agitation at the surface of the water. The water is broken into small droplets and thrown into the air, increasing the contact between air and water. This helps oxygen from the atmosphere dissolve into the waste water.

Mixing Mechanism:

The agitation creates strong currents inside the tank, which:

Mix incoming sewage, return activated sludge (RAS), and oxygen properly

Prevent settling of suspended solids

Types of Aerators:

Vertical surface aerators (move water upward)

Horizontal rotors or brush aerators (used in oxidation ditches)

Advantages:

Simple to install and operate

Lower initial cost

Suitable for shallow tanks

Works well for industrial wastewater

Disadvantages:

Less energy-efficient than diffused aeration systems

Can produce bad odors due to splashing and aerosol formation



Part - C
www.zonetech.in

Note: Attempt all questions. Answer each question in 200 words. Each question carries 20 marks.

33. Water flows at a steady mean velocity of 2 m/s through a 60 mm diameter pipe sloping upwards at 30° to the horizontal. At a section some distance downstream of the inlet, the pressure is 800 kPa and at a section 40 m further along the pipe the pressure is 520 kPa. Determine the average shear stress at the wall of the pipe and at a radius of 15 mm. [Take unit weight of water = 9810 N/m³]

Sol.

$$u = 2 \text{ m / sec.}$$

$$\text{Dia of pipe} = 60 \text{ mm}$$

$$\theta = 30^\circ \text{ (with the Horizontal)}$$

$$P_1 = 800 \text{ kPa}$$

$$P_2 = 520 \text{ kPa}$$

$$L = 40 \text{ m}$$

$$\tau_0 = \text{(wall shear stress)} = ?$$

$$\tau_{y=15 \text{ mm}} = ?$$

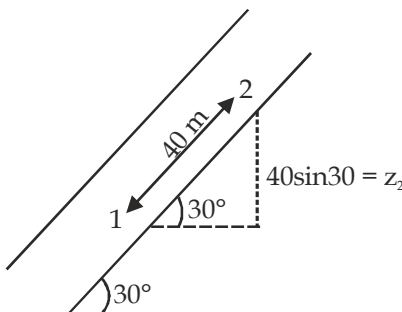

Assuming datum to be passing through the lower point, we have

$$\begin{aligned}
 h_1 - h_2 &= \left(\frac{P_1}{\rho g} + 0 \right) - \left(\frac{P_2}{\rho g} + z_2 \right) \\
 &= \left(\frac{P_1 - P_2}{\rho g} \right) - (z_2 - z_1) \\
 &= \frac{(800 \times 10^3 - 520 \times 10^3)}{10^3 \times 9.81} - (40 \sin 30^\circ - 0) \\
 &= 28.54 - 20 = 8.542 \text{ m}
 \end{aligned}$$

Average shear stress at the wall of the pipe is

$$\begin{aligned}
 \tau_0 &= \left(-\frac{\partial P}{\partial x} \right) \frac{R}{2} \quad \left| \begin{array}{l} \because \text{As we know that} \\ \partial P = \rho g dh \end{array} \right. \\
 \tau_0 &= \rho g \left(-\frac{\partial h}{\partial x} \right) \frac{R}{2} = 9810 \times \frac{8.542}{40} \times \frac{0.030}{2} = 31.423 \frac{\text{N}}{\text{m}^2}
 \end{aligned}$$

Average shear stress at Radius of 15 mm is

$$\tau_{r=15 \text{ mm}} = \rho g \left(-\frac{\partial h}{\partial x} \right) \frac{r}{2} = \frac{9810 \times 8.542 \times 0.015}{40 \times 2} = 15.711 \frac{\text{N}}{\text{m}^2}$$

34. The table below provides contour profile of a reservoir -

Contour	105	100	95	90	85	80	75	70
Area in Hectare	37	33	28	21	19	16	12	7

The Lowest Draw - Down (LDD) of reservoir is 72 meter and volume of water between LDD and top water level is 5.50 million cubic meter, considering trapezoidal approach find out the top water level. What will be the level of water if reservoir is filled with 80% of its full capacity?

Sol.

Lowest draw down level = 72 meter

$$\text{Area at LDD level} = 7 + \frac{12 - 7}{75 - 70} (72 - 70) = 9 \text{ hectare}$$

$$\text{Volume between 72 m to 75 m} = \frac{3}{2} [9 + 12] = 31.5 \text{ hac.m}$$

$$\text{Volume between 75 m to 95 m} = 5 \left[\left(\frac{12 + 28}{2} \right) + 16 + 19 + 21 \right] = 380 \text{ hac.m}$$

$$\begin{aligned}
 \text{Total volume from 72 m to 95 m} &= 411.5 \text{ hac.m} \\
 &= 4115000 \text{ m}^3 \\
 &= 4.115 \text{ Mm}^3
 \end{aligned}$$

$$\begin{aligned}
 \text{Remaining volume upto top} &= 5.5 - 4.115 \text{ Mm}^3 \\
 &= 1.385 \text{ Mm}^3 \\
 &= 138.5 \text{ hac.m}
 \end{aligned}$$

$$\text{Remaining volume} = 138.5 = \frac{x}{2} [A_{95} + A_{TWL}]$$

$$138.5 = \frac{x}{2} \left(28 + \left\{ \left(\frac{33-28}{5} \right) x + 28 \right\} \right)$$

$$x^2 + 56x - 277 = 0$$

$$x = 4.57 \text{ m}$$

$$\text{Hence top water level} = 95 + 4.57 = 99.57 \text{ m}$$

Case- 2

Volume between LLD level & Bottom of Reservoir

$$= \frac{2}{2} [7 + 9] = 16 \text{ hac.m}$$

$$\text{Total capacity of reservoir} = 16 + 550 = 566 \text{ hac.m}$$

$$80\% \text{ volume} = 0.8 \times 566 = 452.80 \text{ hac.m}$$

$$\text{Volume from 70 to 95 m.} = 411.5 + 16 = 427.5 \text{ hac.m}$$

$$\text{Remaining volume} = 452.8 - 427.5 = 25.3 \text{ hac.m}$$

$$\text{Remaining volume} = 25.3 = \frac{x}{2} \left[28 + \left\{ \left(\frac{33-28}{5} \right) x + 28 \right\} \right]$$

$$x^2 + 56x - 50.6 = 0$$

$$x = 0.889$$

$$\text{Hence water level at 80\% capacity} = 95 + 0.889 = 95.889$$

35. A stream of 150 litres per second was delivered from a canal and 110 litres per second was delivered to the field. An area of 2.2 hectares was irrigated in eight hours. The effective depth of root zone was 1.5 m. The runoff loss in the field was 445 m³. The depth of water penetration varied linearly from 1.5 m at the head end of the field to 1.1 m at the tail end. Available moisture holding capacity of the soil is 200 mm per metre depth of soil. Determine the water conveyance efficiency, water application efficiency, water storage efficiency and water distribution efficiency. Irrigation was started at a moisture extraction level of 50%.

Sol.

$$\text{Canal discharge} = 150 \text{ L/s}$$

$$\text{Field discharge} = 110 \text{ L/s}$$

$$A = 2.2 \text{ hac.} = 22000 \text{ m}^2$$

$$\text{Irrigation time} = 8 \text{ hr or } \boxed{28,800 \text{ Sec.}}$$

$$\text{Penetration depth } (D_h) = 1.5 \text{ (Head), } D_{\text{tail}} = 1.1 \text{ m}$$

$$\text{Moisture holding capacity} = 200 \text{ mm/m}$$

$$\text{Root zone depth } (d) = 1.5 \text{ m, loss in runoff} = 445 \text{ m}^3$$

$$\text{Moisture extraction or deficiency} = 50\%$$

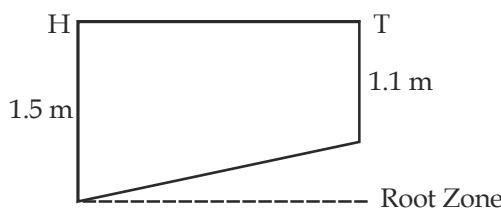

(1) Water conveyance efficiency (η_c)

$$\eta_c = \frac{\text{Field discharge } (Q_f) \times 100}{\text{Canal discharge } (Q_c)}$$

$$\eta_c = \frac{110}{150} \times 100 = 73.33\%$$

(2) Water application efficiency (η_a) -

Water delivered to field = $Q_f \times t = 0.11 \text{ m}^3/\text{sec.} \times 28800 = 3168 \text{ m}^3$

Volume of water stored in root zone -

$$V_s = 3168 - 445 = 2723 \text{ m}^3$$

$$\eta_a = \frac{V_s}{V_f} \times 100 = \frac{2723}{3168} \times 100 = 85.95\%$$

(3) Water storage efficiency (η_s)

Required moisture/m = $200 \text{ mm/m} \times 50\% \text{ deficiency}$
 = $100 \text{ mm/m} = 0.1 \text{ m/m}$

Required total depth = $1.5 \times 0.1 = 0.15 \text{ m}$

Required water = $\text{area} \times \text{depth} = 22,000 \times 0.15 = 3300 \text{ m}^3$

$$\eta_s = \frac{V_s}{V_{\text{Req.}}} \times 100 = \frac{2723}{3300} \times 100 = 82.52\%$$

(4) Water distribution efficiency (η_d):

$$D = \frac{1.5 + 1.1}{2} = 1.3 \text{ m}$$

$$\text{Average deviation} = \frac{|1.5 - 1.3| + |1.1 - 1.3|}{4} = 0.1 \text{ m}$$

$$\eta_d = \left(1 - \frac{0.1}{1.3}\right) \times 100 = 92.31\%$$

36. A subgrade having clay of liquid limit greater than 50 and classified as CH as per Indian Standard Soil Classification System, has to be stabilized with a suitable calcium based stabilizer (either lime or cement). Elaborate the reason for preferring and selecting among lime and cement for stabilizing the soil. Explain the underlying stabilization mechanism and state the expected improvement in engineering properties of the soil after treatment.

Sol. Lime Stabilization of CH Soil (High Plasticity Clay)

Soils classified as CH (inorganic clay of high plasticity) under the Indian Standard Soil Classification System are characterized by high compressibility, pronounced shrink-swell behavior, and low shear strength. In the Indian context, such soils are commonly referred to as black cotton soils. For subgrade applications, these soils require stabilization, and lime is generally preferred over cement as a stabilizing agent.

तेजस Practice Batch

- Most Expected Question handpicked by Faculties
- Subjectwise & Topicwise LIVE Solution
- Get Question & Solution Pdf
- Exclusive OFFLINE Doubt Support

RPSC-AE

UDH

5000+ standard Tech &
2000+ Non-Tech Que

RSSB-JE

B.TECH

3000+ standard Tech &
1500+ Non-Tech Que

RSSB-JE

DIPLOMA

2000+ standard Tech &
1500+ Non-Tech Que

for more info Contact us at :

9828747676, 9462447676

1. Justification for Preference of Lime over Cement

- (i) Suitability for Clayey Soils
Lime is particularly effective for soils with high plasticity ($PI > 15-18$), whereas cement stabilization is more appropriate for granular or low plasticity soils ($LL < 40$).
- (ii) Reduction in Plasticity and Swelling Potential
Lime treatment results in a significant reduction in liquid limit and plasticity index, thereby effectively mitigating the shrink-swell characteristics inherent to CH soils.
- (iii) Immediate Modification and Drying Effect
Quicklime reacts exothermically with water, leading to a reduction in moisture content and rapid improvement in soil workability. This facilitates early construction operations.
- (iv) Chemical Compatibility with Clay Minerals
High plasticity clays, often rich in montmorillonite, exhibit strong reactivity with lime. The reaction with silica and alumina released from clay minerals leads to the formation of stable compounds.
- (v) Self-Healing Characteristics
Lime-stabilized soils exhibit autogenous healing, enabling partial recovery of strength upon subsequent wetting and drying cycles.

2. Mechanism of Lime Stabilization

The stabilization process involves short-term modification and long-term stabilization reactions:

- (A) Short-Term Reactions (Modification Stage)
 - (a) Cation Exchange
Calcium ions (Ca^{2+}) from lime replace monovalent cations (Na^+ , K^+) adsorbed on clay surfaces, resulting in a reduction of the diffuse double layer thickness.
 - (b) Flocculation and Agglomeration
The reduction in repulsive forces leads to aggregation of clay particles, transforming the soil structure from a dispersed to a flocculated state, thereby improving workability and friability.
- (B) Long-Term Reactions (Stabilization Stage)
 - (a) Pozzolanic Reactions
At a pH exceeding 12.4, lime reacts with dissolved silica and alumina liberated from clay minerals.
 - (b) Formation of Cementitious Compounds
These reactions result in the formation of:
Calcium Silicate Hydrate (C-S-H)
Calcium Aluminate Hydrate (C-A-H)
These compounds impart strength and durability by binding soil particles into a rigid matrix.

3. Improvement in Engineering Properties

Upon stabilization with an optimum lime content (typically 4-8% by weight), the following improvements are observed:

- (i) Plasticity Characteristics
Reduction in Liquid Limit (LL)
Increase in Plastic Limit (PL)
Significant decrease in Plasticity Index (PI)
Marked reduction in shrink-swell potential
- (ii) Strength Parameters
Substantial increase in California Bearing Ratio (CBR)
Significant improvement in Unconfined Compressive Strength (UCS), often by an order of magnitude depending on curing duration

- (iii) Workability
Transformation of soil from a plastic, cohesive state to a friable, granular state, facilitating compaction and handling
- (iv) Compressibility
Reduction in compressibility, leading to lower post-construction settlements
- (v) Durability and Moisture Resistance
Enhanced resistance to moisture variations, improving long-term performance under environmental loading conditions

Note: Lime stabilization is particularly well-suited for CH soils due to its ability to induce both immediate modification and long-term strength gain. It effectively reduces plasticity, enhances strength, and improves durability, thereby making it a technically superior and economical choice over cement for stabilizing highly plastic clayey subgrades.

37. Estimate the size of a septic tank (length to width ratio 2.25, liquid depth 2 m with 300 mm freeboard), desludging interval in years and the total trench area (m²) of the percolation field, for a small colony of 300 people. Assume water supply of 100 litres per capita per day, waste water flow at 80% of water consumption, sludge production of 0.04 cubic metre per capita per year and the retention time of 3 days at the start up. Desludging is done when the tank is one-third full of sludge. A percolation test indicated an allowable hydraulic loading of 100 L per square metre per day.

Sol. 1. Septic tank

Given $\frac{L}{B} = 2.25$
 $D = 2\text{m}$
 free board = 0.3m
 Population = 300
 Water supplied = 100 L/capita/day
 waste water flow = 80%
 percolation rate = 100 L/m²/day
 sludge produced per year = 0.04m³/capita/year
 Retention time = 3 days

Water supplied to the colony = 100 × 300 = 30,000 L/d
 Sewage produced = 80% of 30000 = 24,000 L/d
 Sewage retained = 24000 × 3 = 72,000 L = 72 m³

If de-sludging is done when the tank is filled up to 1/3rd of its capacity.

$$\text{Capacity} = \text{sewage retained} + \text{sludge volume retained } C = 72 + \frac{C}{3}$$

$$\therefore \frac{2}{3}C = 72 \text{ m}^3$$

$$C = 108 \text{ m}^3$$

Assume Depth, D = 2 m

$$\text{Area of tank} = 108/2 = 56 \text{ m}^2$$

$$\frac{L}{B} = 2.25$$

$$\therefore L = 2.25 B$$

$$B \times 2.25B = 56$$

$$B = 4.9\text{m}$$

$$L = 2.25 \times 4.9 = 11.10 \text{ m}$$

$$\text{Overall depth} = 2.0 + 0.3 \text{ (freeboard)} = 2.3 \text{ m}$$

$$\text{Hence, dimension of the tank} = 11.10 \text{ m} \times 4.90 \text{ m} \times 2.3 \text{ m}$$

2. Soak well

$$\text{Sludge volume removed in desludging} = \frac{C}{3} = \frac{108}{3} = 36 \text{ m}^3$$

$$\text{sludge produced per year} = 0.04 \text{ m}^3/\text{capita}\cdot\text{year} \times 300 \text{ persons} = 12 \text{ m}^3/\text{year}$$

$$\text{Sewage outflow} = 72 \text{ m}^3$$

$$36 \text{ m}^3 \text{ of sludge will therefore be produced in } \frac{1}{12} \times 36 \text{ years} = 3 \text{ years}$$

$$\text{Hence, desludging interval} = 3 \text{ years}$$

$$\text{Hydraulic loading of percolation trench} = 100 \text{ L/m}^2/\text{day}$$

$$\text{Outflowing sewage per 3 days} = 72 \text{ m}^3$$

$$\text{Outflowing sewage per 1 day} = 24 \text{ m}^3 = 24,000 \text{ L/day}$$

$$\text{Trench area required} = \frac{24,000}{100 \text{ L/m}^2/\text{d}} = 240 \text{ m}^2$$



www.zonetech.in

ZONE TECH
Best Institute For Assistant & Junior Engineer