

Paper Code : 03



ZONE TECH

Best Institute For Assistant & Junior Engineer

RPSC AE MAINS

SOLUTIONS

CIVIL ENGINEERING-I

Paper-III

Exam Date :- **23 March 2025**

Click to Enroll <https://zonetech.in/rpsc-aen>

for more info Contact us at :

9828747676, 9462447676

PAPER-III : CIVIL ENGINEERING PAPER - I

Total Marks: 200
Total Question: 37

Part - A

Note: Attempt all questions. Answer each question in 15 words. Each question carries 2 marks.

1. A certain steel has proportionality limit of 280 N/mm² in simple tension. Under a certain two-dimensional stress system, the principal stresses are 120 N/mm² tensile and 30 N/mm² compressive. Calculate the factor of safety according to maximum shear stress theory. Take Poisson's ratio = 0.30.

Sol. According to maximum shear stress theory

$$\frac{\sigma_1 - \sigma_2}{2} = \frac{f_y}{2.f.o.s.}$$

$$\frac{120 - (-30)}{2} = \frac{280}{2.(f.o.s.)}$$

$$f.o.s. = 1.866$$

2. What is meant by load factor?

Sol. Load factor:- It is define as the ratio of plastic moment to working moment.

$$\text{Load factor} = \frac{M_p}{M} = \frac{f_y}{f} \times \frac{Z_p}{Z_e}$$

$$[L.F = F.O.S. \times S.F.]$$

www.zonetech.in

$$\therefore F.O.S. = \frac{f_y}{f}, S.F. = \frac{Z_p}{Z_e}$$

$$M = f \times \frac{I}{y}$$

$$[M = f.Z_e]$$

3. What is meant by proof stress of Reinforcement Bar?

Sol. Proof stress of a reinforcement bar is the stress required to plastic deformation, it's 0.2% strain in materials lacking a distinct yield point like high strength deformed bars.

4. A simply supported beam AB, having a length of 5 m, is shown in the figure below. Draw the bending moment diagram for the beam with salient values shown.

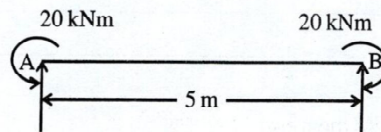

Sol. Support reaction is zero.

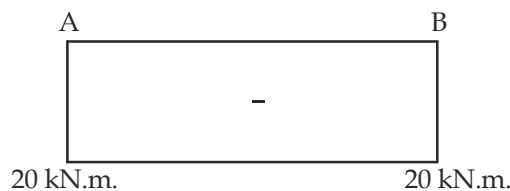

5. If the maximum crushing stress of a punch is 4 times the maximum shearing stress of the plate, then deduce the relationship between smallest hole diameter 'd' and plate thickness 't'.

Sol. When a hole is punched- S.F. on plate = $\tau_{max} \cdot \pi dt$

$$\text{Crushing force on punch} = \sigma_c \cdot \pi d^2 / 4$$

Given $\sigma_c = 4 \tau_{max}$

Since the same force P acts- $\tau_{max} \cdot \pi dt = \sigma_c \cdot \pi d^2 / 4$

$$\tau_{max} \cdot \pi dt = (4 \tau_{max}) \cdot \pi d^2 / 4$$

$$\boxed{dt = d^2} \quad \boxed{d = t}$$

6. State Maxwell's reciprocal theorem.

Sol. **Maxwell's Reciprocal Theorem:-** Deflection at the location of Q due to unit load at P equal to deflection at the location of P due to unit load at Q.

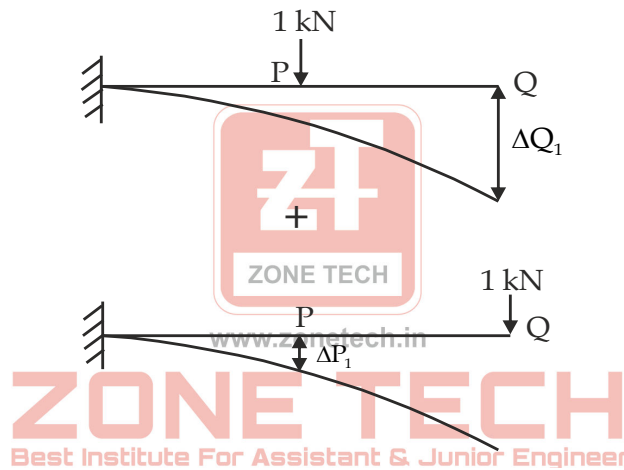

Now as per Maxwell's reciprocal theorem:

$$\Delta Q_1 = \Delta P_1$$

7. State the assumptions to simplify a statically indeterminate framed structure to a statically determinate system using portal method.

Sol. Portal method is approximate method to solve multistorey from which follows following assumption-

- (1) Point of contraflexure lies in mid of every beam & column.
- (2) Horizontal shear is shared in such a way to that interior column takes twice of horizontal force of exterior column.

8. State the Castigliano's Second Theorem.

Sol. **Castigliano's Second Theorem:-** Partial derivative of strain energy with respect to any force is equal to the deflection at that point in the direction of that force.

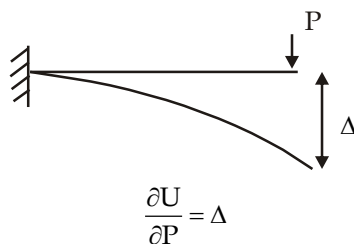

9. Define strain energy in structures.

Sol. Work done to straining a material is called strain energy-
Strain energy stored due to axial load-

$$U_i = \int \frac{P^2 dx}{2AE}$$

Where, P = Axial load
dx = Elemental length
AE = Axial rigidity

Strain energy stored due to bending-

$$U_i = \int \frac{M_x^2 ds}{2EI}$$

Where, M_x = Moment at section x-x
ds = Elemental length
EI = Flexural rigidity
or E = Modulus of elasticity
I = Moment of inertia

10. Construct the influence line diagram for the shear at point C of the beam as shown in figure below.

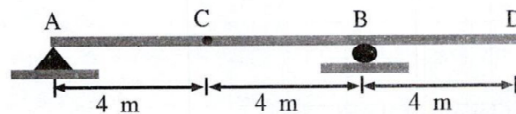

Sol.

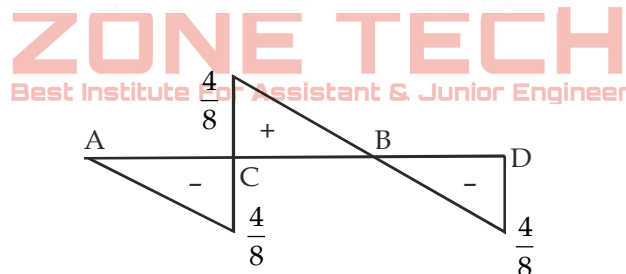

11. Under what condition, is a shear key provided in a reinforced concrete retaining wall?

Sol. For safety against sliding a shear key can be used at bottom of R.W. & in this case F.O.S < 1.5.

12. What is development length of Bars?

Sol. Development length is the minimum length of R/F is to be embedded (inserted) in the the concrete to balance the additional force developed in the tension R/F and for development length the bond stress is taken maximum so it is permissible bond stress.

13. What is characteristic strength of material?

Sol. Characteristic Strength ⇒

⇒ It is that strength which have 95% of probability of having that strength or more than that and only have 5% probability having strength than that particular strength.

OR

⇒ It is that strength which have 95% of probability of being pass the test result and it only have 5% probability of test results to be failed.



ZONE TECH
Best Institute For Assistant & Junior Engineer

RPSC-AE

Urban Development and Housing

UDH

शिखर
Batch

Offline

&

LIVE

Live From Classroom



30 March 2026



08:00 AM

LIVE Batch Features

- 500+ hours of Technical & 200+ hours of Non-Technical Video Lectures of LIVE from OFFLINE CLASS ROOM
- Chapter Wise & topicwise Daily Practice Paper (DPP) / WORKBOOK solution videos
- 40 Mock Papers in exam styled question format for practice
- Exclusive access to the Tejas practice batch featuring 5000+ standard Technical Que and 2000+ Non-Tech Que (Limited Time offer)
- Meet your mentors anytime at our offline centres
- CLASSNOTES, DPP (Workbook), Question Booklet in PDF format of all Subjects .
- Telegram Group for Enrolled Students for Doubt Solving

for more info Contact us at :

9828747676, 9462447676

14. List the pre-tensioning losses in pre-stressed concrete structures.

Sol. Pre-tensioning:

1. Elastic deformation of concrete.
2. Relaxation of steel.
3. Shrinkage of concrete.
4. Creep of concrete.

15. What do you understand by the term "rear counterfort" used in counterfort retaining walls? Explain briefly.

Sol. A rear counterfort (also known as a back counterfort) is a vertical, triangular reinforced concrete brace or rib located on the inside (backfill side) of a counterfort retaining wall. It connects the vertical stem (the face wall) to the base slab (the heel slab) at regular intervals to improve structural stability and efficiency.

It is called a "rear" counterfort because it is hidden on the back side of the retaining wall, unlike buttresses which are placed on the exposed front face.

16. Under what circumstances will block shear failure dominate?

Sol. Block shear failure dominates when both member and connection are high strength and insufficient edge distance, spacing, thickness etc. causing a block of material to tear out under combined shear and tension.

17. Define shape factor.

Sol. Shape Factor (S.F.):-

It is the ratio of plastic moment capacity to yield moment of capacity. S.F. denotes the reserve strength of the beam cross section beyond the yield limit to plastic limit.

$$S.F. = \frac{M_p}{M_e} = \frac{\sigma_y Z_p}{\sigma_y Z_e} = \left[\frac{Z_p}{Z_e} \right]$$

Best Institute For Assistant & Junior Engineer

18. What is the minimum overlap in case of lap joints in welded connections, as per IS: 800-2007?

Sol. Minimum overlap length:-

- The overlap of plates to be fillet welded in a lap joint should not be less than four times the thickness of the thinner part joined or 40 mm, whichever is more.

19. Define 'Compact' cross-sections in steel design, as per IS: 800-2007.

Sol. Compact sections are those sections which can develop moment equal to plastic moment but do not have rotational capability to fail by forming mechanism due to local buckling failure.

20. Why are the end returns provided in fillet weld?

Sol. End returns are extra length of weld provided at the corner to release additional stress due to high stress generated due to dynamic loading as per IS code value should not be less than $2 \times$ size of weld.

Part - B

Note: Attempt all questions. Answer each question in 50 words. Each question carries 05 marks.

21. Draw the Shear Force (S.F.) and Bending Moment (B.M.) diagrams for a simply supported beam of span 8 m. The beam carries a 20 kN point load applied through a bracket. The bracket is fixed to the beam at a distance of 6 m from the left support, and the bracket length in the direction of the beam is 1 m.

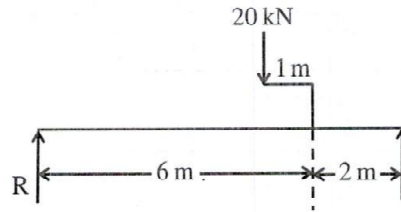

Sol.

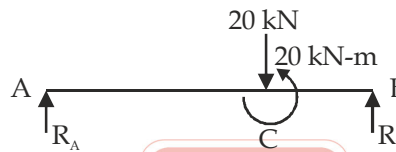

taking moment about B.

$$R_A \times 8 - 20 \times 2 - 20 = 0$$

$$R_A = 7.5 \text{ kN}$$

$$R_B = 12.5 \text{ kN.}$$

Shear Force Dia.

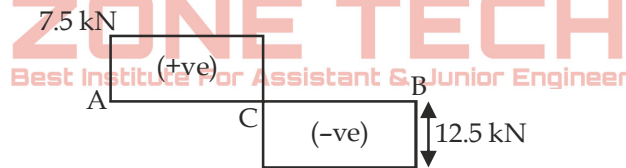

Bending Moment Diagram

$$M_c = 7.5 \times 6 = 45$$

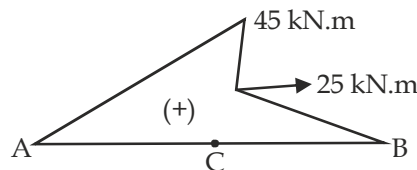

22. A hollow alloy tube 3 m long of 30 mm and 20 mm external and internal diameter respectively, is subjected to a tension. It has shown an elongation of 5.8 mm under a tensile load of 50 kN. Find the Euler's buckling load if the tube is used as column with one end fixed and the other end free.

Sol.

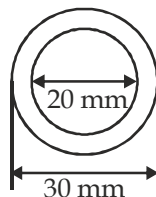

$$\text{Elongation } (\Delta l) = \frac{Pl}{AE}$$

$$A = \frac{\pi}{4}(30^2 - 20^2) = 392.70 \text{ mm}^2$$

$$P = 50 \times 1000 = 50000 \text{ N}$$

$$E = \frac{Pl}{A \cdot \Delta l} = \frac{50000 \times 3000}{392.70 \times 5.8}$$

$$= 65857.217 \text{ N/mm}^2$$

$$\text{Euler's buckling load} = \frac{\pi^2 EI}{L_{\text{eff}}^2}$$

$$L_{\text{eff}} = 2 \times 3 = 6 \text{ m}$$

$$I = \frac{\pi}{64}(30^4 - 20^4) = 31906.8$$

$$P_{\text{cr}} \Rightarrow \frac{\pi^2 \times 65857.217 \times 31906.8}{6000 \times 6000}$$

$$P_{\text{cr}} \Rightarrow 0.576 \text{ kN}$$

23. Describe the standard penetration test and its significance.

Sol. **Standard Penetration Test (SPT)**

The Standard Penetration Test (SPT) is widely used to determine the parameters of the soil in-situ. The test is especially suited for cohesionless soils as a correlation has been established between the SPT value and the angle of internal friction of the soil.

The test consists of driving a split-spoon sampler into the soil through a bore hole 55 to 150 mm in diameter at the desired depth. A hammer of 640 N (65 kg) weight with a free fall of 750 mm is used to drive the sampler. The number of blows for a penetration of 300 mm is designated as the "Standard Penetration Value" or "Number" N. The test is usually performed in three stages. The blow count is found for every 150 mm penetration.

If full penetration is obtained, the blows for the first 150 mm are ignored as those required for the seating drive. The number of blows required for the next 300 mm of penetration is recorded as the SPT value. The test procedure is standardised and set out in the Indian standard "IS: 2131-1972-Standard Penetration Test."

Usually SPT is conducted at every 2 m depth or at the change of stratum. If refusal is noticed at any stage, it should be recorded.

In the case of fine sand or silt below water-table, apparently high values may be noted for N. In such cases, the following correction is recommended (Terzaghi and Peck, 1948).

$$N = 15 + \frac{1}{2}(N' - 15)$$

where

N' = observed SPT value; and

N = corrected SPT value

For SPT made at shallow levels, the values are usually too low. At a greater depth, the same soil, at the same density index, would give higher penetration resistance and hence higher SPT value.

The effect of the overburden pressure on SPT value may be approximated by the equation:

$$N = N' \left[\frac{350}{\bar{\sigma}_0 + 70} \right]$$

where

N' = observed SPT value;

N = corrected SPT value; and

$\bar{\sigma}_0$ = effective overburden pressure in kN/m^2 , not exceeding 280 kN/m^2 .

This implies that no correction is required if the effective overburden pressure is 280 kN/m^2 or more.

24. Calculate the effective stress for a soil element at depth 5 m (i.e. at A point) in a uniform deposit of soil as shown in fig. Take unit weight of water = 9.8 kN/m^3 and specific gravity of soil = 2.7.

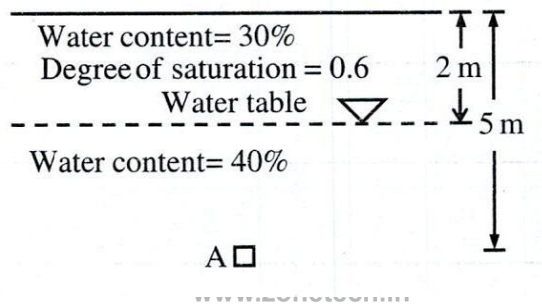

Sol. Above water table

ZONE TECH
Best Institute For Assistant & Junior Engineer

$$eS = wG$$

$$e \times 0.6 = 0.3 \times 2.7$$

$$e = 1.35$$

$$\gamma_t = \left(\frac{G + es}{1 + e} \right) \gamma_w = \left(\frac{2.7 + 1.35 \times 0.6}{1 + 1.35} \right) \times 9.81 = 14.65 \text{ kN/m}^3$$

$$\text{Submerged unit weight } (\gamma_{\text{sub}}) = \left(\frac{G - 1}{1 + e} \right) \gamma_w$$

$$eS = wG$$

$$e = 0.4 \times 2.7 = 1.08$$

$$= \frac{2.7 - 1}{1 + 1.08} \times 9.81$$

$$= 8.017 \text{ kN/m}^3$$

$$\text{Pressure at A} = \gamma_t \times 2 + \gamma_{\text{sub}} \times 3$$

$$= 14.65 \times 2 + 8.017 \times 3$$

$$= 53.35 \text{ kN/m}^2$$



ZONE TECH
Best Institute For Assistant & Junior Engineer

RSSB-JE

संकल्प
Batch

CIVIL ENGG. B.TECH



30 March 2026

Offline
&

LIVE

Live From Classroom



08:00 AM

LIVE Batch Features

- 500+ hours of Technical & 150+ hours of Non-Technical Video Lectures of LIVE from OFFLINE CLASS ROOM
- Chapter Wise & topicwise Daily Practice Paper (DPP) / WORKBOOK solution videos
- 40 Mock Papers in exam styled question format for practice
- Exclusive access to the Tejas practice batch featuring 3000+ standard Technical Que and 2000+ Non-Tech Que (Limited Time offer)
- Meet your mentors anytime at our offline centres
- CLASSNOTES, DPP (Workbook), Question Booklet in PDF format of all Subjects .
- Telegram Group for Enrolled Students for Doubt Solving

for more info Contact us at :

9828747676, 9462447676

25. Determine the reaction at the roller support B of a propped cantilever beam (as shown in the figure below) using force method of analysis. Assume EI is constant for the beam.

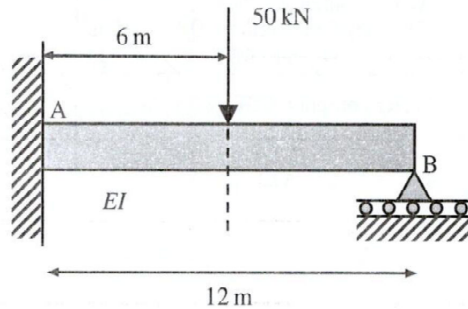

Sol. By consistency deformation method
 net deflection at support B is zero.
 Downward deflection due to external load at B = Upward deflection due to support reaction at B.
 Deflection due to external load at B

$$\Rightarrow \frac{50(6)^3}{3EI} + \frac{50(6)^2 \times 6}{2EI} \quad \dots(i)$$

$$\text{Deflection due to reaction} = \frac{R_B (12)^3}{3EI} \quad \dots(ii)$$

From (i) & (ii)

$$\frac{50(6)^3}{3EI} + \frac{50(6)^3}{2EI} = \frac{R_B (12)^3}{3EI}$$

$$50(6)^3 \left(\frac{1}{3} + \frac{1}{2} \right) = \frac{R_B (12)^3}{3}$$

$$R_B = 15.625 \text{ kN}$$

26. Determine the degree of static indeterminacy of the pin-jointed plane frame shown in figure.

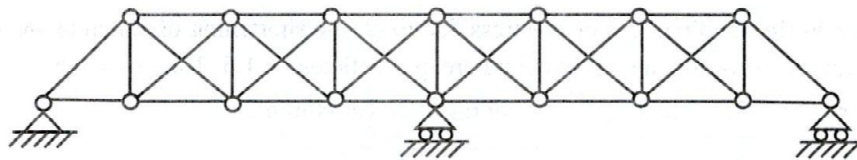

Sol. Static indeterminacy (Ds) = M + r - 2J

M = Number of member

r = Number of support reaction

J = Number of joint

m = 35

r = 4

J = 16

Ds = 35 + 4 - 2 × 16 = 7

27. A concrete beam 150 mm × 300 mm is pre-tensioned by 7 wires of 7 mm diameter at an initial stress of 1000 N/mm² with their centroid located at an eccentricity of 50 mm as shown in fig. Find the loss of prestress due to elastic shortening of concrete and creep of concrete. Use M 40 concrete mix and creep coefficient = 1.6. Take modulus of elasticity of concrete is $E_c = 5000\sqrt{f_{ck}}$. Take $E_{st} = 2 \times 10^5$ N/mm².

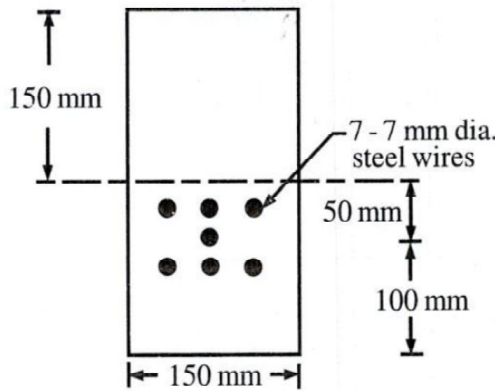

Sol.

$$\text{Area of steel} = 7 \times \frac{\pi}{4} (7)^2 = 269.39 \text{ mm}^2$$

$$\text{Stress} = 1000 \text{ N/mm}^2$$

$$\text{Pre tensioned force (F)} = 269.39 \times 1000 = 269.33 \text{ kN.}$$

$$\text{Loss due to elastic} = mF_c$$

Shorting

$$F_c = \frac{P}{A} + \frac{(F.e)e}{I}$$

$$= \frac{269.39 \times 1000}{150 \times 300} + \frac{269.39 \times 1000 \times 50 \times 50 \times 12}{150 \times (300)^3}$$

$$= 5.986 + 1.995$$

⇒

$$7.98 \text{ N/mm}^2$$

$$m = \frac{2 \times 10^5}{5000\sqrt{40}} = 6.324$$

$$\text{Loss due to elastic shorting} = 6.324 \times 7.98 = 50.469 \text{ N/mm}^2$$

$$\text{Loss due to creep} = mF_c \theta$$

$$= 6.324 \times 7.98 \times 1.6$$

$$= 80.75 \text{ N/mm}^2$$

28. A reinforced concrete beam of width 400 mm and overall depth 600 mm is subjected to a design shear force of 90 kN, design bending moment of 135 kNm, and design twisting moment of 40 kNm. The effective cover on the bottom is 50 mm. As per the provisions of IS: 456-2000, calculate the values of equivalent shear force and equivalent bending moment for which the beam should be designed.

Sol.

$$\text{Equivalent shear } (V_{eq}) = V + 1.6 \frac{T}{B}$$

$$V = 90 \text{ kN}$$

$$T = 40 \text{ kN-m}$$

$$B = 400$$

$$V_{eq} = 90 + 1.6 \times \frac{40 \times 1000}{400}$$

$$V_{eq} = 250 \text{ kN}$$

$$\text{Equivalent moment } (M_{eq}) = M + \frac{T}{1.7} \left(1 + \frac{D}{B} \right)$$

$$= 135 + \frac{40}{1.7} \left(1 + \frac{600}{400} \right)$$

$$= 193.82 \text{ kN-m}$$

29. Determine the shape factor of a given channel section about major axis.

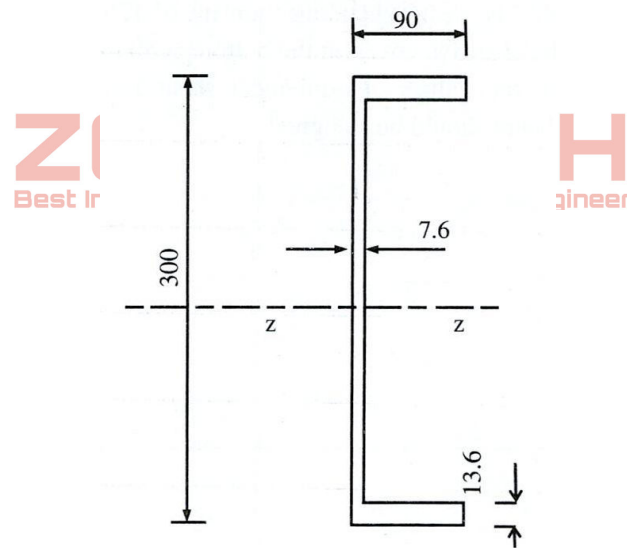

Sol.

$$\text{Shape Factor} = \frac{Z_p \text{ Plastic section modulus}}{Z_e \text{ Elastic section modulus}}$$

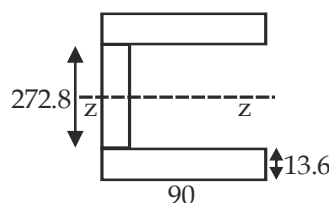

$$I_{zz} = 2 \left(\frac{90(13.6)^3}{12} + 90 \times 13.6 \times (143.2)^2 \right) + 7.6 \frac{(272.8)^3}{12}$$

$$I_{zz} = 63094771.18$$

$$z_e = \frac{63094771.18}{150} = 420631.81 \text{ mm}^3$$

$$z_p = \frac{A}{2} (y_1 + y_2)$$

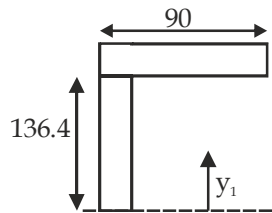

$$y_1 = y_2$$

$$y_1 = \frac{136.4 \times 7.6 \times 68.2 + 90 \times 13.6 \times 143.2}{136.4 \times 7.6 + 90 \times 13.6}$$

$$= 108.807$$

$$A = 272.8 \times 7.6 + 2 \times 90 \times 13.6 = 4521.28$$

$$z_p = \frac{4521.28}{2} (108.807 + 108.807)$$

$$z_p = 491946.913$$

$$\text{Shape factor} = \frac{491946.913}{420631.81} = 1.169$$

30. Explain briefly the parameters on which overall member buckling of beam - column depends.

Sol. Overall member buckling of a beam-column (a structural member experiencing combined axial compression and bending) depends on the interplay between its geometry, material properties, and loading conditions. The primary parameters governing this stability are:

Slenderness Ratio (KL/r):

The most critical factor, defined as the ratio of the effective length (KL) to the radius of gyration (r) of the cross-section. Higher slenderness ratios, caused by long, thin members, increase susceptibility to buckling.

Effective Length (Le = KL):

Depends on end support conditions (e.g., pinned, fixed). Restrained ends (fixed) increase the critical buckling load compared to free ends, as they reduce the effective buckling length.

Bending Stiffness (EI):

The flexural rigidity (E = Modulus of Elasticity, I = Moment of Inertia) directly impacts resistance. Higher stiffness, particularly around the weak axis (minimum I), increases buckling resistance.

Initial Imperfections and Eccentricity:

Real members are not perfectly straight, and loads are rarely perfectly axial. Initial bowing or eccentric loading introduces additional bending moments, initiating early buckling at lower loads.

Axial Load vs. Bending Moment Ratio:

The interaction between the compressive force (P) and bending moment (M). High axial loads increase flexural buckling, while high bending moments can induce lateral-torsional buckling (twisting and sideways bending).

Material Residual Stresses:

Locked-in stresses from manufacturing (rolling/welding) can cause premature yielding, lowering the threshold for inelastic



ZONE TECH
Best Institute For Assistant & Junior Engineer

RSSB-JE

आकाश
Batch

CIVIL ENGG. DIPLOMA



30 March 2026

Offline
&

LIVE

Live From Classroom



08:00 AM

LIVE Batch Features

- 400+ hours of Technical & 150+ hours of Non-Technical Video Lectures of LIVE from OFFLINE CLASS ROOM
- Chapter Wise & topicwise Daily Practice Paper (DPP) / WORKBOOK solution videos
- 30 Mock Papers in exam styled question format for practice
- Exclusive access to the Tejas practice batch featuring 2000+ standard Technical Que and 2000+ Non-Tech Que (Limited Time offer)
- Meet your mentors anytime at our offline centres
- CLASSNOTES, DPP (Workbook), Question Booklet in PDF format of all Subjects .
- Telegram Group for Enrolled Students for Doubt Solving

for more info Contact us at :

9828747676, 9462447676

31. A damper offers resistance 0.08 N at a constant velocity 0.06 m/s. The damper is used with a spring of stiffness equal to 12 N/m. Determine the damping ratio and frequency of the system when the mass of the system is 0.3 kg.

Sol.
$$\text{Damping Coeff.}(C) = \frac{F}{V} = \frac{0.08}{0.06} = \frac{4}{3} \text{ N-s / m}$$

$$\text{Damping ratio } (\xi) \frac{C}{C_{cr}} = \frac{C}{2\sqrt{km}}$$

$$\Rightarrow \xi = \frac{\frac{4}{3}}{2\sqrt{12 \times 0.3}} = \boxed{0.35}$$

$$\Rightarrow \xi < 1 \Rightarrow \text{under damped}$$

$$\Rightarrow \text{Frequency of system } (f_d) = \frac{\omega_n}{2\pi} \sqrt{1 - \xi^2}$$

$$\Rightarrow f_d = \frac{1}{2\pi} \times \sqrt{\frac{k}{m}} \times \sqrt{1 - \xi^2}$$

$$\Rightarrow \boxed{f_d = 0.9429 \text{ Hz}}$$

32. Discuss Single Degree of Freedom System.

Sol. A single degree of freedom system is the simplest mathematical model in structural dynamics where motion and it's effect of any component can be described using a single independent variable.

Equation of an SDOF system →

www.zonetech.in

$$\boxed{m\ddot{u} + c\dot{u} + ku = f(t)}$$



Note: Attempt all questions. Answer each question in 200 words. Each question carries 20 marks.

33. Determine the slope at the ends and at the centre of the beam. Also, calculate the deflection under the load. Use the conjugate beam method.

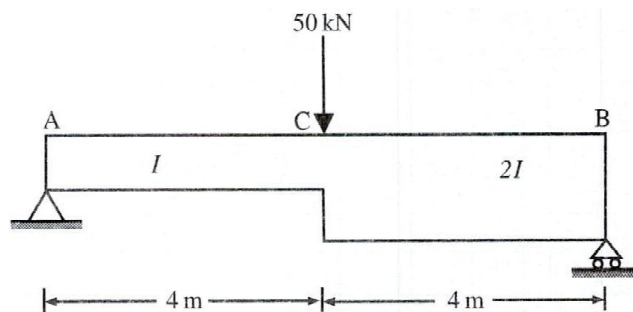

Sol. Calculate Reaction R_A and R_B

$$R_A = 25 \text{ kN} \quad R_B = 25 \text{ kN}$$

Make $\frac{M}{EI}$ Diagram on conjugate Beam.

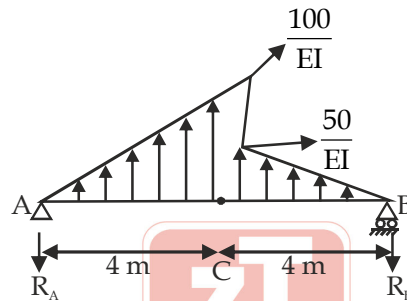
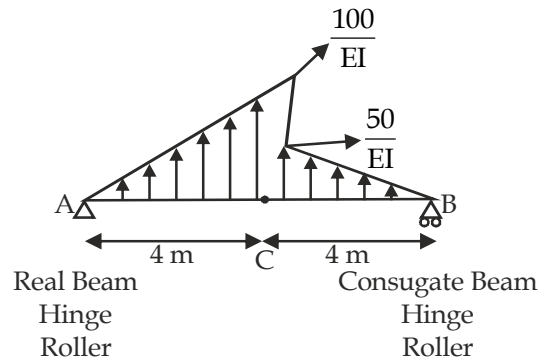

$$R_A + R_B = \frac{1}{2} \times 4 \times \frac{100}{EI} + \frac{1}{2} \times 4 \times \frac{50}{EI}$$

$$R_A + R_B = \frac{200}{EI} + \frac{100}{EI} = \frac{300}{EI}$$

Moment about B.

$$R_A \times 8 = \frac{200}{EI} \times \left(4 + \frac{4}{3}\right) + \frac{100}{EI} \times \frac{8}{3}$$

$$R_A = \frac{500}{3EI}$$

$$R_B = +\frac{400}{3EI}$$

According to conjugate beam method shear force at any point over conjugate beam is equal to slope at that point on real beam and also bending moment is equal to deflection.

$$\text{Slope at A} = -\frac{500}{3EI} \text{ (Clockwise)}$$

$$\text{Slope at B} = -\frac{400}{3EI} \text{ (Clockwise)}$$

$$\text{Slope at C} = -\frac{500}{3EI} + \frac{200}{EI} = +\frac{100}{EI} \text{ (Anticlockwise)}$$

$$\text{Deflection at C} = -\frac{500}{3EI} \times 4 + \frac{200}{EI} \times \frac{4}{3}$$

$$= -\frac{400}{EI} \text{ (Downward)}$$

तेजस Practice Batch

- Most Expected Question handpicked by Faculties
- Subjectwise & Topicwise LIVE Solution
- Get Question & Solution Pdf
- Exclusive OFFLINE Doubt Support

RPSC-AE

UDH

5000+ standard Tech &
2000+ Non-Tech Que

RSSB-JE

B.TECH

3000+ standard Tech &
1500+ Non-Tech Que

RSSB-JE

DIPLOMA

2000+ standard Tech &
1500+ Non-Tech Que

for more info Contact us at :

9828747676, 9462447676

34. A vertical wall 6 m high supports a mass of level soil behind it. The angle of internal friction of 30° . The water table is at a depth of 3 m below the top. The layer of soil on the top 3 m has a unit weight of 18 kN/m^3 , and the layer of soil on the bottom 3 m has a saturated unit weight of 20 kN/m^3 . Calculate the total thrust caused by the soil mass on the wall and its point of application.

Sol.

$$\phi = 30^\circ$$

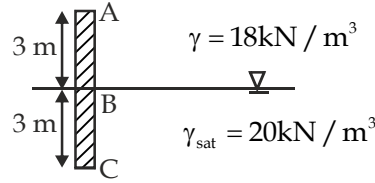

$$K_a = \frac{1 + \sin 30}{1 - \sin 30} = \frac{1}{3}$$

Pressure at B = $K_a \gamma z$

$$= \frac{1}{3} \times 18 \times 3 = 18 \text{ kN/m}^2$$

Pressure at C = $\frac{1}{3} \times 18 \times 3 + \frac{1}{3} \times (20 - 9.81) \times 3 + 3 \times 9.81$
 $= 18 + 10.19 + 29.43$
 $= 57.62 \text{ kN/m}^2$

Pressure Diagram

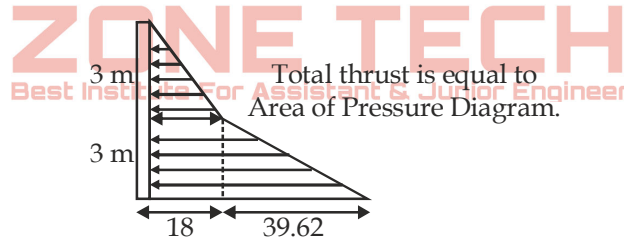

$$\text{Area} = \frac{1}{2} \times 18 \times 3 + \frac{1}{2} (18 + 57.62) \times 3$$

$$= 27 + 113.43$$

$$= 140.43 \text{ kN-m}$$

Point of application: from bottom

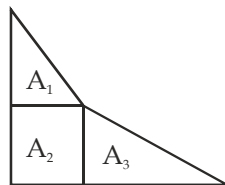

$$A_1 = \frac{1}{2} \times 18 \times 3 = 27$$

$$A_2 = 18 \times 3 = 54$$

$$A_3 = \frac{1}{2} \times 39.62 \times 3 = 59.43$$

$$y_1 = 3 + \frac{3}{3} = 4$$

$$y_2 = 1.5$$

$$y_3 = 1$$

$$\text{Centre of point of application} = \frac{A_1 y_1 + A_2 y_2 + A_3 y_3}{A_1 + A_2 + A_3}$$

$$\Rightarrow \frac{27 \times 4 + 54 \times 1.5 + 59.43 \times 1}{27 + 54 + 59.43} = 1.769$$

35. Analyse the frame shown in figure by slope deflection method and draw bending moment diagram. Flexural Rigidity (EI) is same for all members.

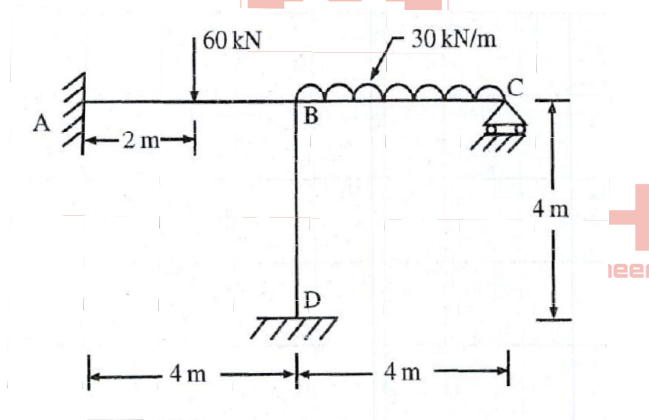

Sol. Fixed end moment

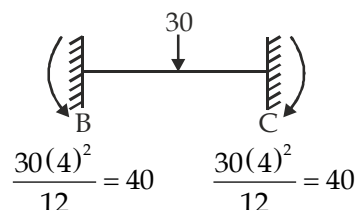
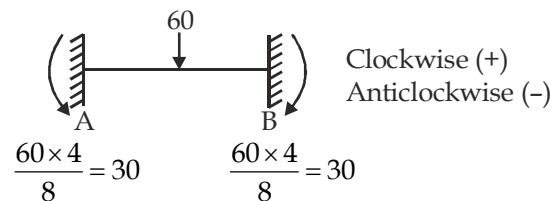

Slope deflection equation

$$M_{AB} = M_{FAB} + \frac{2EI}{l} \left(2\theta_A + \theta_B - \frac{3\delta}{l} \right)$$

$$M_{AB} = -30 + \frac{2EI}{4} (\theta_B) \quad \dots(i)$$

$$M_{BA} = 30 + \frac{2EI}{4} (2\theta_B) \quad \dots(ii)$$

$$M_{BC} = -40 + \frac{2EI}{4} (2\theta_B + \theta_C) \quad \dots(iii)$$

$$M_{CB} = 40 + \frac{2EI}{4} (2\theta_C + \theta_B) \quad \dots(iv)$$

$$M_{BD} = + \frac{2EI}{4} (2\theta_B) = EI\theta_B \quad \dots(v)$$

$$M_{DB} = \frac{2EI}{4} (\theta_B) = 0.5EI\theta_B \quad \dots(vi)$$

Equilibrium equation

$$M_{BA} + M_{BC} + M_{BD} = 0$$

$$30 + EI\theta_B - 40 + EI\theta_B + 0.5EI\theta_C + EI\theta_B = 0$$

$$3EI\theta_B + 0.5EI\theta_C = 10 \quad \dots(vii)$$

⇒

$$M_{CB} = 0$$

$$40 + EI\theta_C + 0.5EI\theta_B = 0$$

$$0.5EI\theta_B + EI\theta_C = -40 \quad \dots(viii)$$

From eq. (vii) & (viii)

$$EI\theta_B = \frac{120}{11} \quad EI\theta_C = -\frac{500}{11}$$

$$M_{BD} = 10.909 \text{ kN-m}$$

$$M_{DB} = 5.45 \text{ kN-m}$$

$$M_{CB} = 40 - \frac{500}{11} + 0.5 \times \frac{120}{11} = 0$$

$$M_{CB} = 0$$

$$M_{BC} = -40 + \frac{120}{11} + 0.5 \left(-\frac{500}{11} \right)$$

$$= -51.81 \text{ kN-m}$$

$$M_{BA} = 30 + \frac{120}{11} = 40.909 \text{ kN-m}$$

$$M_{AB} = -30 + 0.5 \times \frac{120}{11} = -24.545 \text{ kN-m}$$

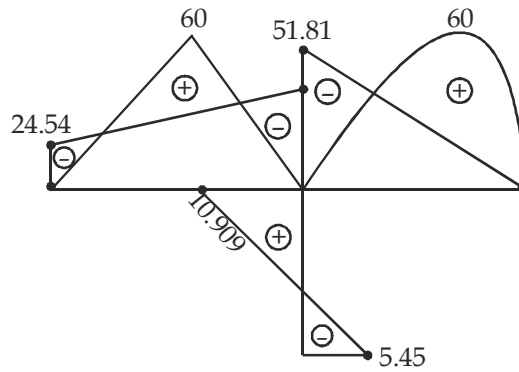

36. (A) A square reinforced concrete axially loaded column is 450 mm × 450 mm in size. The effective length of column is 4.5 m. 8 steel bars of 18 mm diameter are provided for the longitudinal reinforcement. The lateral ties 6 mm have been provided at appropriate spacing. Determine the strength of column. The grade of concrete is M 20 and the quality of steel is HYSD Fe 415. Assumed that the column is laterally tied and eccentricity is within permissible limit. 10 Marks
- (B) Write the provisions of following as per IS 456: 2000.
- (1) Longitudinal Reinforcement in column 4 Marks
 - (2) Lateral Ties in column 3 Marks
 - (3) Helical Reinforcement 3 Marks



www.zonetech.in

Sol. (A)

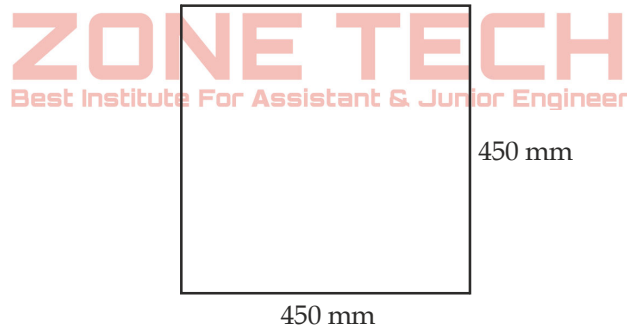

Length = 4.5 m

$$\text{Area of steel} = 8 \times \frac{\pi}{4} (18)^2$$

$$P_u = 0.4 A_c f_{ck} + 0.67 f_y A_{st}$$

$$A_c = 450 \times 450 - \frac{\pi}{4} \times 8 \times (18)^2 = 200464.24$$

$$A_{st} = \frac{\pi}{4} \times 8 \times (18)^2 = 2035.75 \text{ mm}^2$$

$$P_u = 0.4 \times 200464.24 \times 20 + 0.67 \times 415 \times 2035.75$$

$$P_u = 2169.75 \text{ kN}$$

$$\text{Working load} = \frac{2169.75}{1.5} = 1446.50 \text{ kN}$$

(B)

(1)

- Minimum Dia. of Bar = 12 mm.
- Minimum % of R/f = 0.8% of gross Area
- Maximum % of R/f = 6% of gross Area
- Minimum number of Bar in Rectangular = 4
- Minimum number of Bar in Circular = 6

(2)

$$\text{Diameter of Bar} = \frac{\phi_{\text{main}}}{4} (\phi_{\text{main}} = \text{Maximum dia. of main Bar}) \left. \vphantom{\frac{\phi_{\text{main}}}{4}} \right\} \text{Which ever is maximum}$$

= 6 mm

$$\text{Spacing of ties:-} \left. \begin{array}{l} \text{Lateral least Dimension} \\ 16\phi_{\text{main}} \rightarrow \text{Minimum dia. of Bar} \\ 300 \text{ mm.} \end{array} \right\} \text{Which ever is minimum}$$

(3)

$$0.36 \frac{f_{ck}}{f_y} \left(\frac{A_g}{A_c} - 1 \right) \leq \frac{V_b}{V_c}$$

For maximum pitch $\left\{ \begin{array}{l} 75 \text{ mm} \\ \text{or} \\ \frac{D_c}{6} \end{array} \right\}$

where

D_c = Core diameter of column

For minimum pitch $\left\{ \begin{array}{l} 25 \\ 3(\phi_h) \end{array} \right\}$

where ϕ_h is diameter of helical Bar.

37. Determine the collapse load for the cantilever beam shown in the figure below, using plastic theory. Here, M_p is the plastic moment of the section, and L is the total length of the beam.

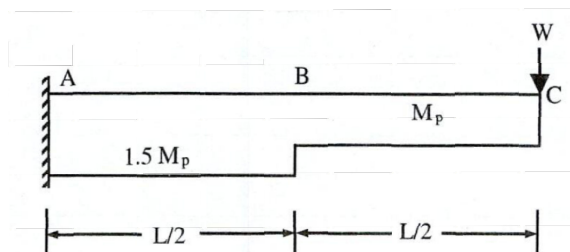

Sol. Degree of static indeterminay (D_s) = 0
 Number of plastic hinges required
 for complete collapse = $D_s + 1$
 = $0 + 1 = 1$

Possible location of plastic hinges = A, B

Case- I

Hinge At 'A'

Mechanism Diagram

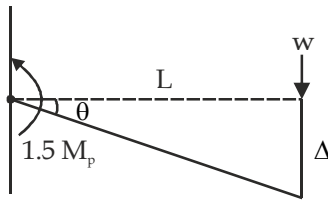

Acc. to principal of virtual workdone

External work done = internal workdone

$$w \times \Delta = 1.5 M_p \times \theta \quad \dots(i)$$

$$L\theta = \Delta \quad \dots(ii)$$

from eq. (i) & (ii)

$$w \times L\theta = 1.5M_p \theta$$

$$w = \frac{1.5M_p}{L}$$

Case- 2

Hinge at B

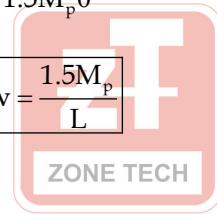

www.zonetech.in

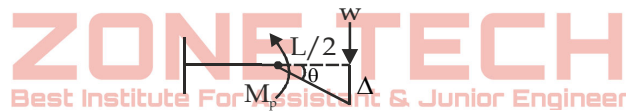

$$M_p \theta = w \Delta \quad \dots(i)$$

$$\frac{L}{2} \theta = \Delta \quad \dots(ii)$$

from eq. (i) & (ii)

$$M_p \theta = \frac{L}{2} \theta w$$

$$w = \frac{2M_p}{L}$$

So, collapse load is $\frac{1.5M_p}{L}$